

XR 300 LS

Part No.: 8300003

- Load Sense

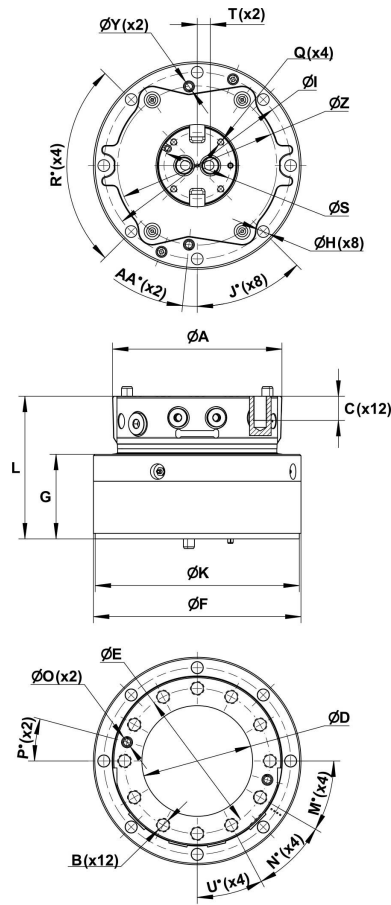
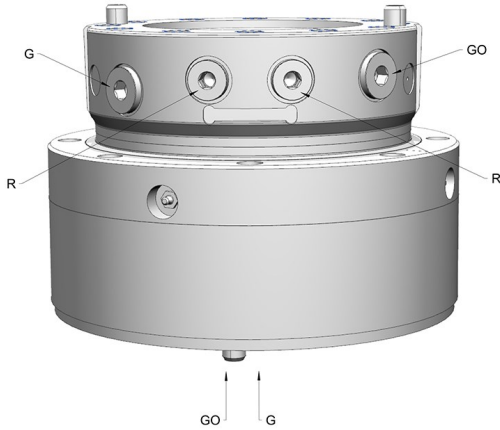

Upper	
G GO:	R:
G 3/4	G 1/2

A: Ø244,7 mm	AA: 6°	B: M20	C: 33 mm	D: Ø160 mm	E: Ø210 mm	F: Ø300 mm	G: 122,3 mm	H: Ø17 mm	I: Ø270 mm	J: 45°	K: Ø295 mm	L: 206,3 mm	M: 30°
N: 32°	O: Ø16 mm	P: 15°	Q: M10	R: 90°	S: Ø96 mm	T: 19 mm	U: 28°	Y: Ø16 mm	Z: Ø230 mm				

		Max 	Max 	Max 	Max 		Max 	Max 	Max 	Max 	Max
77 kg	360°	±300 kN ¹	±90 kN	±70 kN	±17 kNm ²	3000 Nm	28 l/min	25 MPa	35 MPa	35 MPa	35 MPa

¹ Max axial load static indicate theoretical max load for hanging applications without accelerations.

² The torque load may not be combined with axial load.

A rotator with the shortening LS is not equipped with restrictors (unlike our standard rotators). This means that the oil flow from the base machine has to be adapted.

Pressure limiting valves fitted in the motor.

Can be supplemented with hose guard.

Oil distributor ordered separately.

We reserve the right to make product changes. For further technical information relating to integration and hydraulic connections, please contact rotator@indexator.com