

XR 350 LS

Part No.: 8350000

- Load Sense

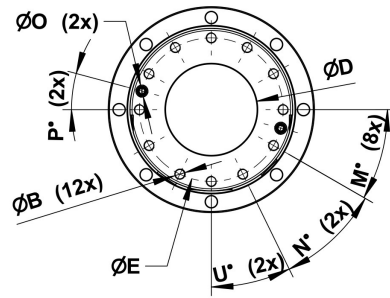
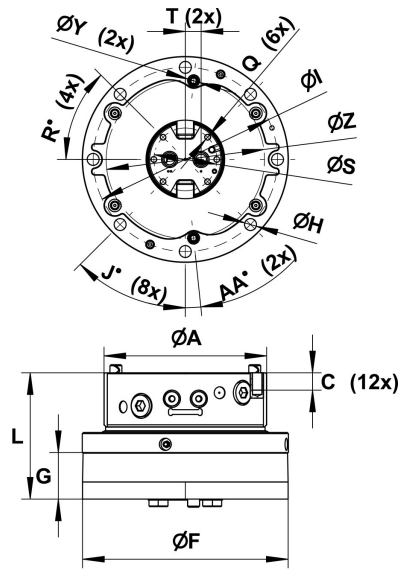
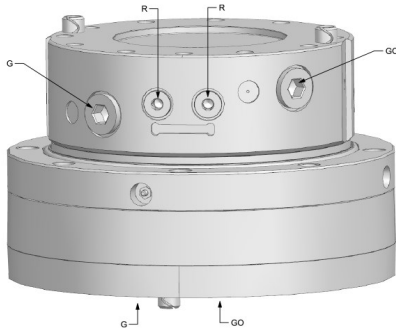

Upper	
G G0:	R:
G 1	G 1/2

A: Ø300 mm	AA: 6°	B: M20	C: 32 mm	D: Ø170 mm	E: Ø265 mm	F: Ø379 mm	G: 123 mm	H: Ø22 mm	I: Ø340 mm	J: 45°	L: 233 mm	M: 30°	N: 34°
O: Ø22 mm	P: 15°	Q: M12	R: 45°	S: Ø116 mm	T: 29 mm	U: 26°	Y: Ø22 mm	Z: 292 mm					

121 kg	360°	±500 kN ¹	±150 kN	±110 kN	±39 kNm ²	4350 Nm	35 l/min	25 MPa	40 MPa	40 MPa	40 MPa

¹ Max axial load static indicate theoretical max load for hanging applications without accelerations.

² The torque load may not be combined with axial load.

A rotator with the shortening LS is not equipped with restrictors (unlike our standard rotators). This means that the oil flow from the base machine has to be adapted.

Pressure limiting valves fitted in the motor.

Can be supplemented with hose guard.

Oil distributor ordered separately.

We reserve the right to make product changes. For further technical information relating to integration and hydraulic connections, please contact rotator@indexator.com